



Bulletin No. 210466
June 2007
Supersedes January 2007



SEER - up to 16.50
3 to 5 Tons

Cooling Capacity - 33,000 to 60,000 Btuh

MODEL NUMBER IDENTIFICATION

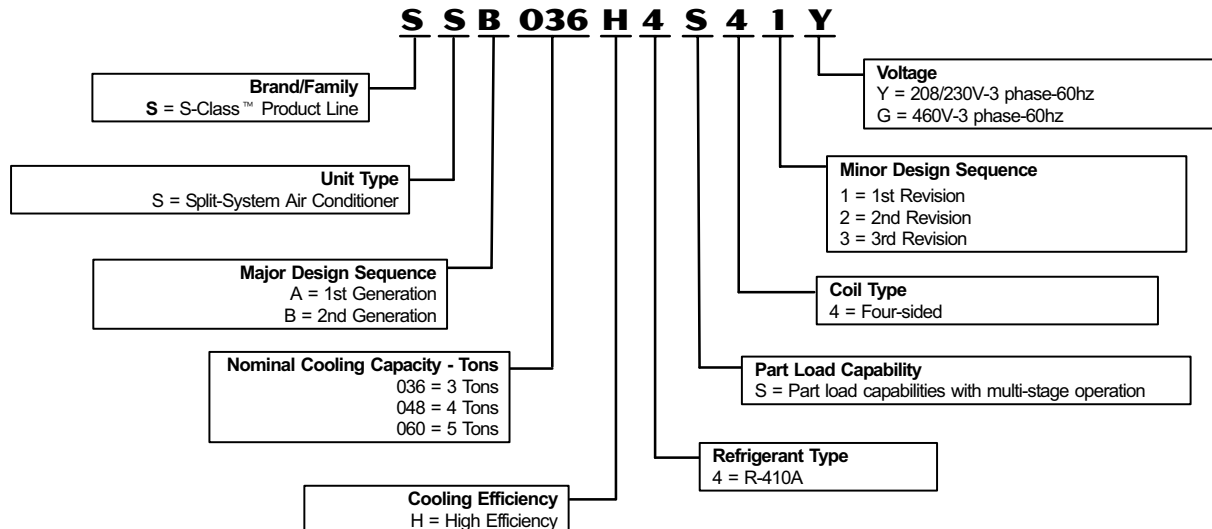

FEATURES

CONTENTS

ARI Ratings	Pages 9-14
Commercial Control Systems	Pages 5
Dimensions	Page 7
Electrical Data	Page 6
Features	Pages 2-4
Guide Specifications	Pages 15-19
Indoor Coil/Air Handler Substitution	Page 8
Installation Clearances	Page 5
Model Number Identification	Page 1
Optional Accessories	Page 6
Sound Data	Page 8
Specifications	Page 6

EQUIPMENT WARRANTY

Compressor - limited warranty for **five years** in non-residential installations.

All other covered components - **one year** in non-residential installations.

Refer to Lennox Equipment Limited Warranty certificate included with unit for specific details.

APPROVALS

Certified in accordance with USE certification program which is based on ARI Standard 210/240-2005.

Sound rated in Lennox reverberant sound test room in accordance with test conditions included in ARI Standard 270-95.

Tested in the Lennox Research Laboratory environmental test room.

Rated according to U.S. Department of Energy (DOE) test procedures.

Air conditioners and components within bonded for grounding to meet safety standards for servicing required by UL and the Canadian Electrical Code (CEC).

Units are UL and ULC listed.

ISO 9001 Registered Manufacturing Quality System.

ENERGY STAR® certified units are designed to use less energy, help save money on utility bills, and help protect the environment.

APPLICATIONS

SEER up to 16.50.

3 through 5 ton.

Three-phase power supply.

Sound levels as low as 76 dB.

Vertical air discharge allows concealment behind shrubs at grade level or out of sight on a roof.

Matching add-on furnace indoor coils or air handlers provide a wide range of cooling capacities and applications. See ARI Ratings tables.

See Indoor Coils and Air Handlers tab sections for data.

Units shipped completely factory assembled, piped, and wired. Each unit is test operated at the factory insuring proper operation.

Installer must set air conditioner, connect refrigerant lines, and make electrical connections to complete job.

For expanded ratings, see www.lennoxcommercial.com.

REFRIGERATION SYSTEM

Refrigerant

Non-chlorine, ozone friendly, R-410A.

Unit pre-charged with refrigerant.

See Specification table.



1 Outdoor Coil Fan

Direct drive fan moves large air volumes uniformly through entire condenser coil for high refrigerant cooling capacity.

Vertical air discharge minimizes operating sounds and eliminates damage to lawn and shrubs.

Fan motor has sleeve bearings and is inherently protected.

Motor totally enclosed for maximum protection from weather, dust and corrosion

Fan guard constructed of corrosion-resistant PVC (polyvinyl chloride) coated steel.

Fan service access accomplished by removal of fan guard.

2 Copper Tube/Enhanced Fin Coil

Lennox designed and fabricated coil.

Ripple-edged aluminum fins.

Copper tube construction.

Lanced fins provide maximum exposure of fin surface to air stream resulting in excellent heat transfer.

Fin collars grip tubing for maximum contact area.

Flared shoulder tubing connections/silver soldering construction.

Coil is factory tested under high pressure to insure leakproof construction.

Entire coil is accessible for cleaning.

3 High Pressure Switch

Shuts off unit if abnormal operating conditions cause the discharge pressure to rise above setting.

Protects compressor from excessive condensing pressure.

Manual reset.

FEATURES

REFRIGERATION SYSTEM (CONTINUED)

4 Low Pressure Switch

Shuts off unit if suction pressure falls below setting. Provides loss of charge and freeze-up protection. Automatic reset.

5 Hi-Capacity Liquid Line Drier

Factory installed in the liquid line, the drier traps moisture or dirt that could contaminate the refrigerant system. 100% molecular-sieve bead type drier.

OPTIONS

Expansion Valve Kits

Must be ordered extra and field installed on certain indoor units. See ARI Ratings tables. Chatleff style fitting.

Freezestat

Installs on or near the discharge line of the indoor coil or on the suction line.

Senses suction line temperature and cycles the compressor off when suction line temperature falls below its setpoint.

Opens at 29°F and closes at 58°F.

Refrigerant Line Sets

Refrigerant lines (suction & liquid) are shipped refrigeration clean. Lines are cleaned, dried, pressurized, and sealed at factory.

Suction line fully insulated.

L15 lines are stubbed at both ends.

See Specifications table for selection.

Not available for -060 model and must be field fabricated.

COMPRESSOR

6 Copeland Scroll Ultra Tech™ Two-Stage Compressor

Compressor features high efficiency with uniform suction flow, constant discharge flow and high volumetric efficiency and quiet operation.

Compressor consists of two involute spiral scrolls matched together to generate a series of crescent shaped gas pockets between them. During compression, one scroll remains stationary while the other scroll orbits around it.

Gas is drawn into the outer pocket, the pocket is sealed as the scroll rotates.

As the spiral movement continues, gas pockets are pushed to the center of the scrolls. Volume between the pockets is simultaneously reduced.



When pocket reaches the center, gas is now at high pressure and is forced out of a port located in the center of the fixed scrolls. During compression, several pockets are compressed simultaneously resulting in a smooth continuous compression cycle. Continuous flank contact, maintained by centrifugal force, minimizes gas leakage and maximizes

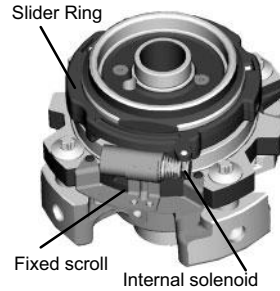

efficiency.

Scroll compressor is tolerant to the effects of slugging and contaminants. If this occurs, scrolls separate, allowing liquid or contaminants to be worked toward the center and discharged.

On the fixed scroll there are two bypass ports in the first suction pocket. On the outside of the fixed scroll there is a "slider ring" that is controlled by an internal solenoid that will rotate and cover the bypass ports. When the thermostat calls for first-stage cooling, the bypass ports are open and the compressor operates at 67% capacity, creating more cost-effective and efficient compressor operation. The bypassed refrigerant is returned to the compressor housing through the bypass ports. When the thermostat calls for second-stage cooling, the internal solenoid is energized, the slider ring rotates and covers the bypass ports, and the compressor operates at full capacity.

Low gas pulses during compression reduces operational sound levels.

Compressor motor is internally protected from excessive current and temperature.

Compressor is installed in the unit on specially formulated, resilient rubber mounts for better sound dampening and vibration free operation.

Crankcase Heater

Crankcase heater prevents migration of liquid refrigerant into compressor and ensures proper compressor lubrication.

FEATURES

7 CABINET

Heavy-gauge steel construction
Pre-painted cabinet finish.
Painted base section.
Control box is conveniently located with all controls factory wired.
Large removable panel provides service access.
Drainage holes are provided in base section for moisture removal.
High density polyethylene unit support feet raise the unit off of the mounting surface, away from damaging moisture.

8 SmartHinge™ Louvered Coil Protection

Steel louvered panels provides complete coil protection.
Panels are hinged to allow easy cleaning and servicing of coils.
Panels may be completely removed.
Interlocking tabs and slots assure tight fit on cabinet.



Refrigerant Line Connections, Electrical Inlets and Service Valves

Suction and liquid lines are located on corner of unit cabinet and are made with sweat connections. See dimension drawing.

- 9 Fully serviceable brass service valves prevent corrosion and provide access to refrigerant system. Suction valve can be fully shut off, while liquid valve may be front seated to manage refrigerant charge while servicing system. Suction and liquid line service valves and gauge ports are located inside the cabinet.
Refrigerant line connections and field wiring inlets are located in one central area of the cabinet. See dimension drawing.

CONTROLS

OPTIONS

Indoor Blower Speed Relay Kit

Relay kit provides optimum humidity control conditions by automatically reducing indoor blower speed during continuous fan or first-stage compressor operation.

L Connection® Network

Complete building automation control system for single or multi-zone applications. Options include local interface, software for local or remote communication, and hardware for networking other control functions. See L Connection Network Engineering Handbook Bulletin for details.

Low Ambient Control Options

Air conditioners operate satisfactorily down to 45°F outdoor air temperature without any additional controls.

Two low ambient control options are available for field installation:

Low Ambient Control Kit (30°F)

Allows unit operation down to 30°F. See Optional Accessories, page 6, for ordering information.

Low Ambient Control Kit (0°F)

Allows unit operation down to 0°F. This option requires that the outdoor fan motor and capacitor be changed. See Low Ambient Control Option table, page 6, for ordering information.

A Freezestat should be installed on compressors equipped with a low ambient kit.

A Compressor Low Ambient Cut-off should be added to terminate compressor operation below recommended operation conditions (on/off operation, 30°F or modulating operation, 0°F).

Indoor Blower Off Delay Relay

Delays the indoor blower-off time during the cooling cycle. See ARI Rating Tables for usage.

OPTIONAL CONVENTIONAL TEMPERATURE CONTROL SYSTEMS - FIELD INSTALLED

COMMERCIAL TOUCHSCREEN THERMOSTAT



Intuitive Touchscreen Interface - **Two Stage Heating / Two Stage Cooling Conventional or Heat Pump** - Seven Day Programmable - Four Time Periods/Day - Economizer Output - Title 24 Compliant - ENERGY STAR® Qualified - Backlit Display - Automatic Changeover

C0STAT02AE1L

Sensors For Touchscreen Thermostat

1 Remote non-adjustable wall mount 20k temperature sensor	C0SNZN01AE1-
1 Remote non-adjustable wall mount 10k averaging temperature sensor	C0SNZN73AE1-
1 Remote non-adjustable duct mount temperature sensor	C0SNDC00AE1-
Outdoor temperature sensor	C0SNSR03AE1-

Accessories For Touchscreen Thermostat

Locking cover (clear)	C0MISC15AE1-
-----------------------------	--------------

¹ Remote sensors for C0STAT02AE1L can be applied in the following combinations: (1) C0SNZN01AE1-, (2) C0SNZN73AE1-, (2) C0SNZN01AE1- and (1) C0SNZN73AE1-, (4) C0SNZN01AE1-, (3) C0SNZN01AE1- and (2) C0SNZN73AE1.

DIGITAL NON-PROGRAMMABLE THERMOSTATS



Intuitive Interface - Automatic Changeover - Simple Up and Down Temperature Control

Two-stage heating / cooling conventional systems	C0STAT10AE1L
---	--------------

Sensor For Digital Non-Programmable Thermostats Above

Remote wall mounted temperature sensor	C0SNZN00AE1-
--	--------------



Intuitive Interface - Automatic Changeover - Backlit Display - Simple Up and Down Temperature Control

One-stage heating / cooling conventional systems	C0STAT12AE1L
---	--------------

Sensor For Digital Non-Programmable Thermostats Above

Outdoor temperature sensor	C0SNSR04AE1-
----------------------------------	--------------

Accessories For Digital Non-Programmable Thermostats Above

Optional wall mounting plate	C0MISC17AE1-
------------------------------------	--------------

INSTALLATION CLEARANCES

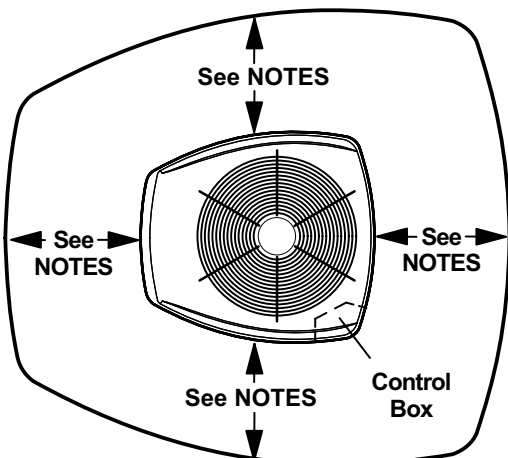

NOTES:

Service clearance of 30 in. (762 mm) must be maintained on one of the sides adjacent to the control box.

Clearance to one of the other three sides must be 36 in. (914 mm)

Clearance to one of the remaining two sides may be 12 in. (305 mm) and the final side may be 6 in. (152 mm).

A clearance of 24 in. (610 mm) must be maintained between two units.

48 in. (1219 mm) clearance required on top of unit.

SPECIFICATIONS

General Data	Model No.	SSB036H4	SSB048H4	SSB060H4
	Nominal Tonnage	3	4	5
Connections (sweat)	Liquid line (o.d.) - in.	3/8	3/8	3/8
	Suction line (o.d.) - in.	7/8	7/8	1-1/8
Refrigerant	¹ R-410A charge furnished	8 lb. 9 oz.	11 lb. 4 oz.	14 lb. 2 oz.
Outdoor Coil	Net face area - sq. ft. Outer coil	16.33	21.00	24.93
	Inner coil	15.76	20.27	24.14
	Tube diameter - in.	5/16	5/16	5/16
	No. of rows	2	2	2
	Fins per inch	22	22	22
Outdoor Fan	Diameter - in.	22	22	26
	No. of blades	4	4	3
	Motor hp	1/6	1/4	1/3
	Cfm	3060	3955	4380
	Rpm	845	835	850
	Watts	215	320	280
Shipping Data - lbs. 1 pkg.		229	257	309

ELECTRICAL DATA

Line voltage data - 60hz		208/230V-3ph	460V-3ph	208/230V-3ph	460V-3ph	208/230V-3ph	460V-3ph
² Maximum overcurrent protection (amps)		25	10	30	15	40	20
³ Minimum circuit ampacity		15.1	6.2	18.6	9.1	23.9	12.3
Compressor	Rated load amps	11.15	4.48	13.46	6.41	17.62	8.97
	Locked rotor amps	58	29	88	41	135	62
	Power factor	0.99	0.99	0.99	0.99	0.99	0.99
Outdoor Fan Motor	Full load amps	1.1	0.6	1.7	0.9	1.8	1.0
	Locked Rotor amps	2.1	1.1	3.1	2.1	2.9	2.0

OPTIONAL ACCESSORIES - MUST BE ORDERED EXTRA

Compressor Low Ambient Cut-Off	45F08	•	•	•
Compressor Time-Off Control	47J27	•	•	•
Freezestat	3/8 in. tubing	93G35	•	•
	5/8 in. tubing	50A93	•	•
Indoor Blower Off Delay Relay	58M81	•	•	•
Indoor Blower Speed Relay Kit	40K58	•	•	•
Low Ambient Kit (down to 30°F)	34M72	•	•	•
Low Ambient Control Option (down to 0°F)		See table below	See table below	See table below
Refrigerant Line Sets	L15-65-30	L15-65-40	•	•
		L15-65-50		
	Field Fabricate			•

NOTE - Extremes of operating range are plus 10% and minus 5% of line voltage.

¹ Refrigerant charge sufficient for 15 ft. length of refrigerant lines.

² HACR type breaker or fuse.

³ Refer to National or Canadian Electrical Code manual to determine wire, fuse and disconnect size requirements.

LOW AMBIENT CONTROL OPTION (Down to 0°F)

Order one each: Speed Control Kit, Weatherproof Kit, Outdoor Fan Motor and Capacitor

Model No.		SSB036H4	SSB048H4	SSB060H4
Speed Control Kit	X5867	•	•	•
Weatherproof Kit	56N41	•	•	•
Outdoor Fan Motor	1/2 HP - 208/230V	69H75	•	•
	460V	69H76	•	•
Capacitor	with bracket	53H06	•	•

DIMENSIONS – INCHES (MM)

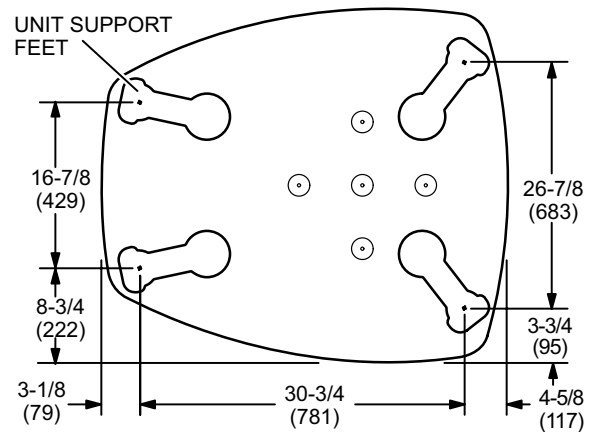
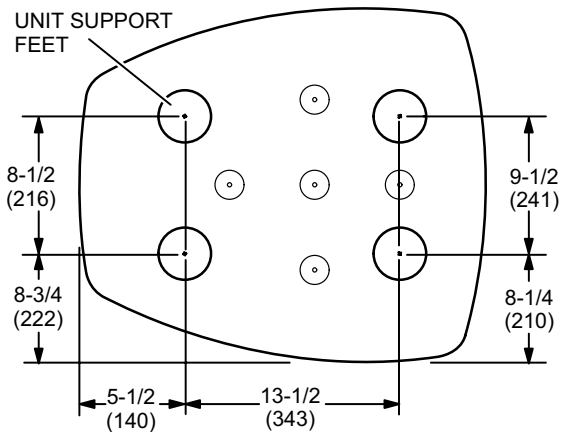
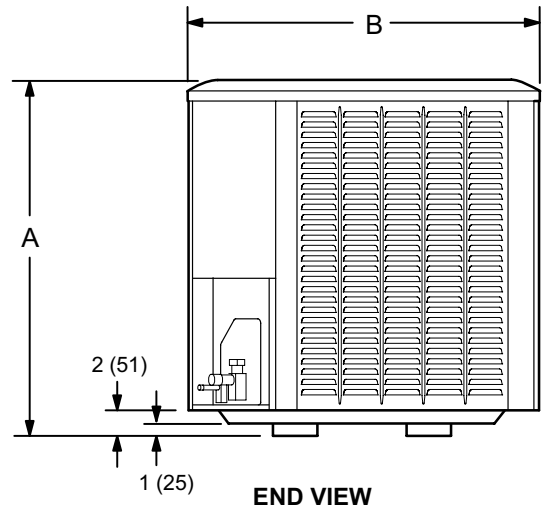
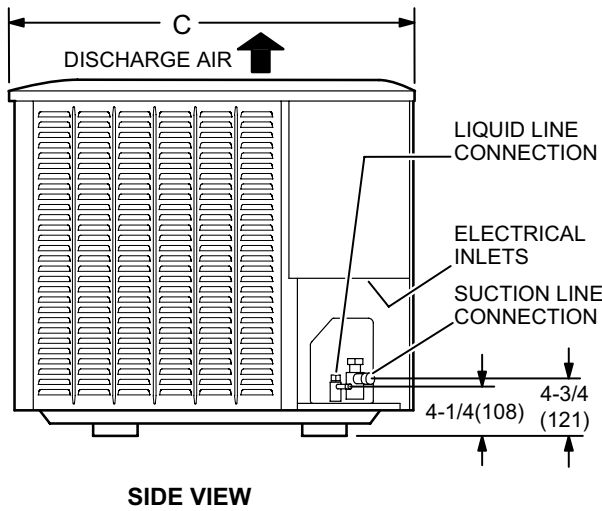
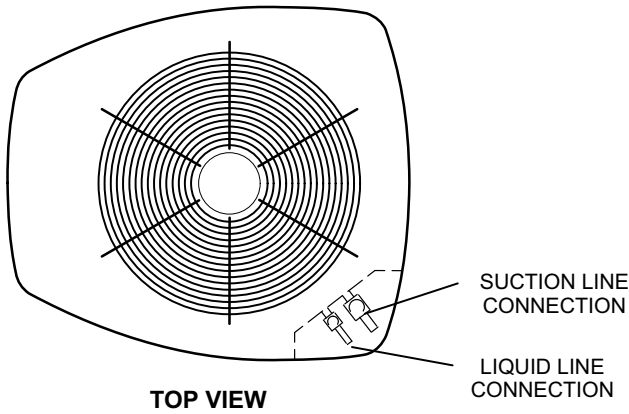

SSB036H4 TO SSB048H4 BASE SECTION

SSB060H4 BASE SECTION

Model No.	A		B		C	
	in.	mm	in.	mm	in.	mm
SSB036H4	31	787	30-1/2	775	35	889
SSB048H4	39	991	30-1/2	775	35	889
SSB060H4	39	991	35-1/2	902	39-1/2	1003

OUTDOOR SOUND DATA

1 Unit Model No.	Octave Band Sound Power Levels dBA, re 10 ⁻¹² Watts								1Sound Rating Number (dB)
	Center Frequency - HZ								
	63	125	250	500	1000	2000	4000	8000	
SSB036H4	81.5	70.5	72.5	73.5	68.5	64.5	60.5	60	76
SSB048H4	81.5	72	72	72.5	68.5	64.5	59.5	56.5	76
SSB060H4	79	71	70.5	76.5	71	65	61.5	57.5	78

NOTE - the octave sound power data does not include tonal correction.

¹ Tested according to ARI Standard 270-95 test conditions.

ARI RATINGS - INDOOR COIL / AIR HANDLER SUBSTITUTION

Substituting Coils in the ARI Tables

Most R-22 and R-410A indoor coils and air handlers are the same except for the factory installed expansion device. C33 coils can be used in place of the CX34 coils, CB26UH-R, CB30M and CB31MV air handlers can be used in place of the CB26XUH, CBX32M and CBX32MV, respectively.

The expansion device is based on the size of the outdoor unit. The factory installed RFC or TXV on the C33/CB26UH-R/CB31MV/CB30M must be replaced to correspond to the outdoor unit. The correct TXV's are:

3 ton air conditioners	37L51
4-5 ton air conditioners	91M02

Example:

A four-ton air conditioner is being installed. The ARI table shows that CBX32MV-048 is a matching air handler. A CB31MV-51 with a 91M02 TXV can be used in its place.

UP-FLOW COILS

	R-410A	R-22
CX34-18/24A-6F	=	C33-24A-2
CX34-18/24B-6F	=	C33-24B-2
CX34-18/24C-6F	=	C33-24C-2
CX34-19A-6F	=	C33-19A-2
CX34-25A-6F	=	C33-25A-2
CX34-25B-6F	=	C33-25B-2
CX34-30A-6F	=	C33-30A-2
CX34-30B-6F	=	C33-30B-2
CX34-30C-6F	=	C33-30C-2
CX34-31A-6F	=	C33-31A-2
CX34-31B-6F	=	C33-31B-2
CX34-36A-6F	=	C33-36A-2
CX34-36B-6F	=	C33-36B-2
CX34-36C-6F	=	C33-36C-2
CX34-38A-6F	=	C33-38A-2
CX34-38B-6F	=	C33-38B-2
CX34-42B-6F	=	C33-42B-2
CX34-43B-6F	=	C33-43B-2
CX34-43C-6F	=	C33-43C-2
no equivalent		C33-44C-2
CX34-44/48B-6F	=	C33-48B-2
CX34-44/48C-6F	=	C33-48C-2
CX34-49C-6F	=	C33-49C-2
CX34-50/60C-6F	=	C33-50/60C-2
CX34-60D-6F	=	C33-60D-2
CX34-62C-6F	=	C33-62C-2
CX34-62D-6F	=	C33-62D-2

AIR HANDLERS

	R-410A	R-22
CBX26UH-018	=	CB26UH-018-R
CBX26UH-024	=	CB26UH-024-R
CBX26UH-030	=	CB26UH-030-R
CBX26UH-036	=	CB26UH-036-R
CBX26UH-042	=	CB26UH-042-R
CBX26UH-048	=	CB26UH-048
CBX26UH-060	=	CB26UH-060-R
CBX32M-018/024	=	CB30M-21/26
CBX32M-030	=	CB30M-31
CBX32M-036	=	CB30M-41
CBX32M-042	=	CB30M-46
CBX32M-048	=	CB30M-51
CBX32M-060	=	CB30M-65
CBX32MV-018/024		no equivalent
CBX32MV-024/030		no equivalent
CBX32MV-036	=	CB31MV-41
CBX32MV-048	=	CB31MV-51
CBX32MV-060	=	CB31MV-65
CBX32MV-068		no equivalent

ARI RATINGS

1 ARI Standard 210/240 Ratings				Indoor Unit Model No.	Expansion Device
Cooling Capacity Btuh	Efficiency		Total Unit Watts		
	SEER	EER			
SSB036H4				3 TON	
Up-Flow Indoor Coils				Up-Flow Coils	
33,000	13.70	10.95	3020	³ CX34-36A/B/C-6F	Factory TXV
33,000	13.70	10.95	3020	³ CX34-42B-6F	² 37L51
33,600	14.00	11.00	3030	³ CX34-38A/B-6F	Factory TXV
33,800	14.00	11.00	3030	³ CX34-44/48B/C-6F	² 37L51
34,400	14.20	11.20	3040	³ CX34-43B/C-6F	² 37L51
Up-Flow Indoor Coils + Furnace				Up-Flow Coils + Furnace	
33,200	15.00	11.20	2970	CX34-36B-6F	⁴ G61MPV-36B-045 Factory TXV
33,200	15.00	11.20	2970	CX34-42B-6F	⁴ G61MPV-36B-045 ² 37L51
33,200	15.20	11.20	2925	CX34-36B-6F	⁴ G61MPV-36B-070 Factory TXV
33,200	15.20	11.20	2925	CX34-42B-6F	⁴ G61MPV-36B-070 ² 37L51
33,200	15.20	11.50	2855	CX34-36C-6F	⁴ G61MPV-36C-090 Factory TXV
33,400	15.20	11.20	2925	CX34-36A-6F	⁴ G60UHV-36A-070 Factory TXV
33,400	15.50	11.50	2865	CX34-36B-6F	⁴ G60UHV-36B-090 Factory TXV
33,400	15.50	11.50	2865	CX34-42B-6F	⁴ G60UHV-36B-090 ² 37L51
33,800	15.20	11.20	2980	CX34-38B-6F	⁴ G61MPV-36B-045 Factory TXV
33,800	15.20	11.50	2935	CX34-38B-6F	⁴ G61MPV-36B-070 Factory TXV
33,800	15.50	11.70	2870	CX34-36C-6F	⁴ G60UHV-60C-110 Factory TXV
34,000	15.50	11.50	2935	CX34-38A-6F	⁴ G60UHV-36A-070 Factory TXV
34,000	15.50	11.50	2940	CX34-44/48B-6F	⁴ G61MPV-36B-070 ² 37L51
34,000	15.70	11.70	2880	CX34-36C-6F	⁴ G60UHV-60C-090 Factory TXV
34,200	15.20	11.20	2985	CX34-44/48B-6F	⁴ G61MPV-36B-045 ² 37L51
34,200	15.70	11.70	2865	CX34-44/48C-6F	⁴ G61MPV-36C-090 ² 37L51
34,200	15.70	11.70	2865	C33-44C	⁴ G61MPV-36C-090 ² 37L51
34,200	15.70	11.70	2875	CX34-38B-6F	⁴ G60UHV-36B-090 Factory TXV
34,400	16.00	12.00	2855	CX34-44/48B-6F	⁴ G60UHV-36B-090 ² 37L51
34,600	15.70	11.70	2945	CX34-43B-6F	⁴ G61MPV-36B-070 ² 37L51
34,800	15.50	11.50	2990	CX34-43B-6F	⁴ G61MPV-36B-045 ² 37L51
34,800	16.00	12.00	2890	C33-44C	⁴ G60UHV-60C-090 ² 37L51
34,800	16.00	12.20	2855	C33-44C	⁴ G60UHV-60C-110 ² 37L51
34,800	16.20	12.20	2850	CX34-44/48C-6F	⁴ G60UHV-60C-110 ² 37L51
35,000	16.00	12.00	2885	CX34-43B-6F	⁴ G60UHV-36B-090 ² 37L51
35,000	16.00	12.00	2895	CX34-44/48C-6F	⁴ G60UHV-60C-090 ² 37L51
35,200	16.00	12.00	2890	⁵ CX34-43C-6F	⁴ G60UHV-60C-110 ² 37L51
35,200	16.00	12.00	2920	CX34-43C-6F	⁴ G61MPV-36C-090 ² 37L51
35,400	16.20	12.20	2900	CX34-43C-6F	⁴ G60UHV-60C-090 ² 37L51
Down-Flow Indoor Coils				Down-Flow Coils	
33,000	13.70	10.95	3020	³ CR33-48B/C-F	² 37L51
33,400	14.00	11.00	3025	³ CR33-30/36A/B/C-F	² 37L51
Down-Flow Indoor Coils + Furnace				Down-Flow Coils + Furnace	
33,600	15.20	11.20	2935	CR33-30/36B-F	⁴ G61MPV-36B-070 ² 37L51
33,600	15.20	11.20	2965	CR33-30/36A-F	⁴ G60DFV-36A-070 ² 37L51
33,600	15.20	11.20	2975	CR33-30/36B-F	⁴ G61MPV-36B-045 ² 37L51
33,800	15.50	11.70	2860	CR33-30/36C-F	⁴ G61MPV-36C-090 ² 37L51
33,800	15.70	11.70	2850	CR33-30/36B-F	⁴ G60DFV-36B-090 ² 37L51

¹ Certified in accordance with USE certification program which is based on ARI Standard 210/240; 95°F outdoor air temperature, 80°F db / 67°F wb entering evaporator air with 25 ft. of connecting refrigerant lines.

² **Factory installed RFC or expansion valve on indoor unit MUST be replaced with expansion valve kit (ordered separately).**

³ Blower must be capable of time-off blower delay. Indoor Blower Off Delay Relay (58M81) is recommended for field installation.

⁴ Blower control must be set for a time-off blower delay.

⁵ Most popular indoor coil.

ARI RATINGS

¹ ARI Standard 210/240 Ratings

Cooling Capacity Btuh	Efficiency		Total Unit Watts	Indoor Unit Model No.	Expansion Device	
	SEER	EER				
SSB036H4					3 TON	
Horizontal Indoor Coils				Horizontal Coils		
33,000	13.70	10.95	3020	³ CH33-36B-2F	² 37L51	
33,400	14.00	11.00	3025	³ CH33-36C-2F	² 37L51	
33,800	14.00	11.00	3030	³ CH23-65	² 37L51	
33,800	14.00	11.00	3030	³ CH33-42B-2F	² 37L51	
34,200	14.20	11.20	3035	³ CH33-44/48B-2F	² 37L51	
34,200	14.20	11.20	3035	³ CH33-48C-2F	² 37L51	
34,400	14.20	11.20	3070	³ CH33-43C-2F	² 37L51	
35,000	14.20	11.20	3125	³ CH33-43B-2F	² 37L51	
Horizontal Indoor Coils + Furnace				Horizontal Coils + Furnace		
33,000	15.20	11.20	2925	CH33-36B-2F	⁴ G61MPV-36B-070	² 37L51
33,200	15.00	11.20	2970	CH33-36B-2F	⁴ G61MPV-36B-045	² 37L51
33,400	15.50	11.50	2865	CH33-36B-2F	⁴ G60UHV-36B-090	² 37L51
33,800	15.50	11.70	2860	CH33-36C-2F	⁴ G61MPV-36C-090	² 37L51
34,000	15.20	11.20	2980	CH33-42B-2F	⁴ G61MPV-36B-045	² 37L51
34,000	15.50	11.50	2940	CH33-42B-2F	⁴ G61MPV-36B-070	² 37L51
34,200	15.70	11.70	2875	CH33-36C-2F	⁴ G60UHV-60C-110	² 37L51
34,200	15.70	11.70	2875	CH33-42B-2F	⁴ G60UHV-36B-090	² 37L51
34,400	15.50	11.50	2985	CH33-44/48B-2F	⁴ G61MPV-36B-045	² 37L51
34,400	15.70	11.70	2885	CH33-36C-2F	⁴ G60UHV-60C-090	² 37L51
34,400	15.70	11.70	2945	CH33-44/48B-2F	⁴ G61MPV-36B-070	² 37L51
34,600	15.70	12.00	2870	CH33-48C-2F	⁴ G61MPV-36C-090	² 37L51
34,600	16.00	12.00	2880	CH33-44/48B-2F	⁴ G60UHV-36B-090	² 37L51
35,000	16.00	12.00	2915	CH33-43C-2F	⁴ G61MPV-36C-090	² 37L51
35,200	15.50	11.50	3060	CH33-43B-2F	⁴ G61MPV-36B-045	² 37L51
35,200	15.70	11.70	3010	CH33-43B-2F	⁴ G61MPV-36B-070	² 37L51
35,200	15.70	11.70	3010	CH33-43B-2F	⁴ G61MPV-36B-071	² 37L51
35,200	16.00	12.20	2890	CH33-48C-2F	⁴ G60UHV-60C-110	² 37L51
35,400	16.00	12.00	2950	CH33-43B-2F	⁴ G60UHV-36B-090	² 37L51
35,400	16.20	12.20	2895	CH33-48C-2F	⁴ G60UHV-60C-090	² 37L51
Air Handlers				Air Handlers		
31,600	12.80	10.40	3035	³ CB29M-41 (Multi-Position)	² 37L51	
33,200	13.50	11.00	3030	³ CB29M-46 (Multi-Position)	² 37L51	
33,600	14.70	11.20	2935	³ CBX32M-030 (Multi-Position)	Factory TXV	
33,800	14.70	11.20	2950	³ CBX32M-036 (Multi-Position)	Factory TXV	
33,800	15.70	11.70	2885	⁴ CBX32MV-024/030 (Multi-Position)	Factory TXV	
34,000	14.70	11.50	2920	³ CBX32M-042 (Multi-Position)	² 37L51	
34,000	14.70	11.50	2945	CBX26UH-030 (Up-Flow / Horizontal)	Factory TXV	
34,200	14.50	11.50	2955	CBX26UH-036 (Up-Flow / Horizontal)	² 37L51	
34,200	14.50	11.50	2975	³ CB30U-41/46 (Up-Flow)	² 37L51	
34,200	15.70	12.00	2850	⁴ CBX27UH-036 (Up-Flow / Horizontal)	² 37L51	
34,200	16.00	11.70	2885	⁴ CBX32MV-036 (Multi-Position)	Factory TXV	
35,200	16.20	12.50	2815	⁴ CBX27UH-042 (Up-Flow / Horizontal)	² 37L51	
35,200	16.50	12.50	2820	⁴ CBX32MV-048 (Multi-Position)	² 37L51	

¹ Certified in accordance with USE certification program which is based on ARI Standard 210/240; 95°F outdoor air temperature, 80°F db / 67°F wb entering evaporator air with 25 ft. of connecting refrigerant lines.

² Factory installed RFC or expansion valve on indoor unit MUST be replaced with expansion valve kit (ordered separately).

³ Blower must be capable of time-off blower delay. Indoor Blower Off Delay Relay (58M81) is recommended for field installation.

⁴ Blower control must be set for a time-off blower delay.

⁵ Most popular indoor coil.

ARI RATINGS

1 ARI Standard 210/240 Ratings						
Cooling Capacity Btuh	Efficiency		Total Unit Watts	Indoor Unit Model No.		Expansion Device
	SEER	EER				
SSB048H4						4 TON
Up-Flow Indoor Coils				Up-Flow Coils		
45,500	13.70	11.20	4005	3 CX34-44/48B/C-6F		Factory TXV
46,500	13.70	11.20	4055	3 CX34-50/60C-6F		2 91M02
46,500	14.00	11.50	4020	3 CX34-60D-6F		2 91M02
47,000	14.20	11.50	4030	3 CX34-62D-6F		2 91M02
47,000	14.20	11.70	4025	3 CX34-49C-6F		2 91M02
47,500	14.20	11.70	4035	3 CX34-62C-6F		2 91M02
Up-Flow Indoor Coils + Furnace				Up-Flow Coils + Furnace		
45,500	14.50	11.50	3920	C33-44C	4 G61MPV-60C-110	2 91M02
45,500	14.50	11.50	3925	CX34-44/48C-6F	4 G61MPV-60C-110	Factory TXV
45,500	14.70	11.50	3925	C33-44C	4 G61MPV-60C-090	2 91M02
45,500	14.70	11.50	3930	CX34-44/48C-6F	4 G61MPV-60C-090	Factory TXV
45,500	14.70	11.70	3880	C33-44C	4 G60UHV-60C-110	2 91M02
45,500	15.00	11.70	3880	CX34-44/48C-6F	4 G60UHV-60C-110	Factory TXV
45,500	15.00	11.70	3880	C33-44C	4 G60UHV-60C-090	2 91M02
46,000	14.70	11.70	3930	CX34-50/60C-6F	4 G61MPV-60C-110	2 91M02
46,000	15.00	11.70	3930	CX34-50/60C-6F	4 G61MPV-60C-090	2 91M02
46,000	15.00	11.70	3885	CX34-44/48C-6F	4 G60UHV-60C-090	2 91M02
46,500	15.00	11.70	3885	CX34-50/60C-6F	4 G60UHV-60C-110	2 91M02
46,500	15.20	11.70	3890	CX34-50/60C-6F	4 G60UHV-60C-090	2 91M02
47,000	15.50	12.20	3850	CX34-60D-6F	4 G61MPV-60D-135	2 91M02
47,000	15.70	12.20	3800	CX34-60D-6F	4 G60UHV-60D-135	2 91M02
47,500	15.00	12.00	3905	CX34-49C-6F	4 G61MPV-60C-110	2 91M02
47,500	15.20	12.00	3915	CX34-49C-6F	4 G61MPV-60C-090	2 91M02
47,500	15.50	12.20	3855	CX34-62D-6F	4 G61MPV-60D-135	2 91M02
47,500	15.50	12.20	3865	CX34-49C-6F	4 G60UHV-60C-110	2 91M02
47,500	15.50	12.20	3870	CX34-49C-6F	4 G60UHV-60C-090	2 91M02
47,500	15.70	12.50	3800	CX34-62D-6F	4 G60UHV-60D-135	2 91M02
48,000	15.50	12.20	3915	CX34-62C-6F	4 G61MPV-60C-110	2 91M02
48,000	15.70	12.20	3875	CX34-62C-6F	4 G60UHV-60C-110	2 91M02
48,000	15.70	12.20	3920	CX34-62C-6F	4 G61MPV-60C-090	2 91M02
48,000	16.00	12.00	3955	5 CX34-62C-6F	4 G60UHV-60C-090	2 91M02
Down-Flow Indoor Coils				Down-Flow Coils		
44,500	13.20	11.00	3995	3 CR33-48B/C-F		2 91M02
46,000	13.70	11.20	4010	3 CR33-50/60C-F		2 91M02
46,000	13.70	11.20	4010	3 CR33-60D-F		2 91M02
Down-Flow Indoor Coils + Furnace				Down-Flow Coils + Furnace		
44,500	14.20	11.20	3910	CR33-48C-F	4 G61MPV-60C-110	2 91M02
44,500	14.50	11.20	3915	CR33-48C-F	4 G61MPV-60C-090	2 91M02
44,500	14.70	11.70	3810	CR33-48C-F	4 G60DFV-60C-090	2 91M02
45,000	14.70	11.50	3875	CR33-48C-F	4 G60DFV-60C-110	2 91M02
46,000	15.20	11.70	3900	CR33-50/60C-F	4 G61MPV-60C-090	2 91M02
46,500	15.00	11.70	3895	CR33-50/60C-F	4 G61MPV-60C-110	2 91M02
46,500	15.20	12.00	3840	CR33-60D-F	4 G61MPV-60D-135	2 91M02
46,500	15.20	12.00	3860	CR33-50/60C-F	4 G60DFV-60C-110	2 91M02
46,500	15.50	12.00	3840	CR33-60D-F	4 G60DFV-60D-135	2 91M02
47,000	15.20	12.20	3855	CR33-50/60C-F	4 G60DFV-60C-090	2 91M02

¹ Certified in accordance with USE certification program which is based on ARI Standard 210/240; 95°F outdoor air temperature, 80°F db / 67°F wb entering evaporator air with 25 ft. of connecting refrigerant lines.

² Factory installed RFC or expansion valve on indoor unit MUST be replaced with expansion valve kit (ordered separately).

³ Blower must be capable of time-off blower delay. Indoor Blower Off Delay Relay (58M81) is recommended for field installation.

⁴ Blower control must be set for a time-off blower delay.

⁵ Most popular indoor coil.

ARI RATINGS

¹ ARI Standard 210/240 Ratings

Cooling Capacity Btuh	Efficiency		Total Unit Watts	Indoor Unit Model No.	Expansion Device	
	SEER	EER				
SSB048H4					4 TON	
Horizontal Indoor Coils				Horizontal Coils		
45,000	13.50	11.20	4000	³ CH23-51	² 91M02	
45,500	13.70	11.20	4005	³ CH23-65	² 91M02	
46,000	14.00	11.20	4015	³ CH33-48C-2F	² 91M02	
46,500	14.00	11.50	4015	³ CH33-60D-2F	² 91M02	
47,000	14.00	11.50	4020	³ CH33-62D-2F	² 91M02	
47,000	14.20	11.70	4015	³ CH33-49C-2F	² 91M02	
47,000	14.20	11.70	4025	³ CH23-68	² 91M02	
47,000	14.20	11.70	4025	³ CH33-50/60C-2F	² 91M02	
Horizontal Indoor Coils + Furnace				Horizontal Coils + Furnace		
46,500	14.70	11.70	3935	CH33-48C-2F	⁴ G61MPV-60C-110	² 91M02
46,500	15.00	11.70	3935	CH33-48C-2F	⁴ G61MPV-60C-090	² 91M02
46,500	15.20	11.70	3890	CH33-48C-2F	⁴ G60UHV-60C-090	² 91M02
46,500	15.20	11.70	3890	CH33-48C-2F	⁴ G60UHV-60C-110	² 91M02
47,000	15.00	11.70	3940	CH33-50/60C-2F	⁴ G61MPV-60C-110	² 91M02
47,000	15.20	11.70	3945	CH33-50/60C-2F	⁴ G61MPV-60C-090	² 91M02
47,000	15.20	12.00	3900	CH33-50/60C-2F	⁴ G60UHV-60C-110	² 91M02
47,000	15.50	12.20	3795	CH33-60D-2F	⁴ G60UHV-60D-135	² 91M02
47,000	15.50	12.20	3795	CH33-62D-2F	⁴ G60UHV-60D-135	² 91M02
47,000	15.50	12.20	3845	CH33-60D-2F	⁴ G61MPV-60D-135	² 91M02
47,500	15.00	11.50	4130	CH33-49C-2F	⁴ G61MPV-60C-091	² 91M02
47,500	15.00	12.00	3960	CH33-49C-2F	⁴ G61MPV-60C-110	² 91M02
47,500	15.00	11.70	4060	CH33-49C-2F	⁴ G61MPV-60C-111	² 91M02
47,500	15.20	12.00	3960	CH33-49C-2F	⁴ G61MPV-60C-090	² 91M02
47,500	15.50	12.20	3895	CH33-49C-2F	⁴ G60UHV-60C-090	² 91M02
47,500	15.50	12.20	3895	CH33-49C-2F	⁴ G60UHV-60C-110	² 91M02
47,500	15.50	12.20	3850	CH33-62D-2F	⁴ G61MPV-60D-135	² 91M02
47,500	15.50	12.20	3900	CH33-50/60C-2F	⁴ G60UHV-60C-090	² 91M02
Air Handlers				Air Handlers		
44,500	12.70	10.70	4140	³ CB29M-51 (Multi-Position)	² 91M02	
44,500	13.60	10.90	4080	³ CB29M-65 (Multi-Position)	² 91M02	
46,000	14.20	11.70	3940	³ CB30U-51 (Up-Flow)	² 91M02	
46,500	15.50	12.20	3810	⁴ CBX27UH-060 (Up-Flow / Horizontal)	Factory TXV	
47,000	14.70	12.00	3900	³ CBX32M-048 (Multi-Position)	Factory TXV	
47,000	15.70	12.20	3840	⁴ CBX32MV-048 (Multi-Position)	Factory TXV	
47,000	15.70	12.20	3850	⁴ CBX27UH-048 (Up-Flow / Horizontal)	Factory TXV	
47,500	14.50	11.70	3980	³ CBX32M-060 (Multi-Position)	Factory TXV	
47,500	14.50	11.70	4015	³ CB30U-65 (Up-Flow)	² 91M02	
47,500	15.70	12.20	3845	⁴ CBX32MV-060 (Multi-Position)	Factory TXV	
47,500	15.70	12.50	3790	⁴ CBX32MV-068 (Multi-Position)	Factory TXV	
48,000	14.70	11.70	4030	CBX26UH-042 (Up-Flow / Horizontal)	² 91M02	
48,000	14.70	12.00	4000	CBX26UH-048 (Up-Flow / Horizontal)	Factory TXV	

¹ Certified in accordance with USE certification program which is based on ARI Standard 210/240; 95°F outdoor air temperature, 80°F db / 67°F wb entering evaporator air with 25 ft. of connecting refrigerant lines.

² **Factory installed RFC or expansion valve on indoor unit MUST be replaced with expansion valve kit (ordered separately).**

³ Blower must be capable of time-off blower delay. Indoor Blower Off Delay Relay (58M81) is recommended for field installation.

⁴ Blower control must be set for a time-off blower delay.

ARI RATINGS

¹ ARI Standard 210/240 Ratings				Indoor Unit Model No.	Expansion Device
Cooling Capacity Btuh	Efficiency		Total Unit Watts		
	SEER	EER			
SSB060H4				5 TON	
Up-Flow Indoor Coils				Up-Flow Coils	
57,000	13.50	11.00	5145	³ CX34-50/60C-6F	Factory TXV
58,000	13.70	11.20	5160	³ CX34-60D-6F	Factory TXV
58,500	13.70	11.20	5165	³ CX34-49C-6F	Factory TXV
58,500	13.70	11.20	5165	³ CX34-62D-6F	Factory TXV
59,500	14.00	11.50	5180	³ CX34-62C-6F	Factory TXV
Up-Flow Indoor Coils + Furnace				Up-Flow Coils + Furnace	
57,000	14.00	11.00	5140	CX34-50/60C-6F	⁴ G61MPV-60C-110 Factory TXV
57,000	14.20	11.00	5125	CX34-50/60C-6F	⁴ G61MPV-60C-090 Factory TXV
57,000	14.20	11.20	5085	CX34-50/60C-6F	⁴ G60UHV-60C-090 Factory TXV
57,000	14.20	11.20	5085	CX34-50/60C-6F	⁴ G60UHV-60C-110 Factory TXV
58,000	14.50	11.20	5115	CX34-49C-6F	⁴ G61MPV-60C-090 Factory TXV
58,500	14.20	11.20	5120	CX34-49C-6F	⁴ G61MPV-60C-110 Factory TXV
58,500	14.70	11.50	5020	CX34-60D-6F	⁴ G61MPV-60D-135 Factory TXV
58,500	14.70	11.50	5065	CX34-49C-6F	⁴ G60UHV-60C-110 Factory TXV
58,500	14.70	11.50	5070	CX34-49C-6F	⁴ G60UHV-60C-090 Factory TXV
59,000	14.70	11.70	5030	CX34-62D-6F	⁴ G61MPV-60D-135 Factory TXV
59,000	15.00	11.70	5025	CX34-60D-6F	⁴ G60UHV-60D-135 Factory TXV
59,500	14.50	11.50	5130	CX34-62C-6F	⁴ G61MPV-60C-110 Factory TXV
59,500	14.70	11.50	5130	CX34-62C-6F	⁴ G61MPV-60C-090 Factory TXV
59,500	15.00	11.70	5080	CX34-62C-6F	⁴ G60UHV-60C-110 Factory TXV
60,000	15.00	11.70	5080	⁵ CX34-62C-6F	⁴ G60UHV-60C-090 Factory TXV
60,000	15.20	11.70	5035	CX34-62D-6F	⁴ G60UHV-60D-135 Factory TXV
Down-Flow Indoor Coils				Down-Flow Coils	
57,000	13.50	11.00	5150	³ CR33-60D-F	² 91M02
Down-Flow Indoor Coils + Furnace				Down-Flow Coils + Furnace	
57,000	14.50	11.20	5040	CR33-60D-F	⁴ G61MPV-60D-135 ² 91M02
57,500	14.50	11.20	5020	CR33-60D-F	⁴ G60DFV-60D-135 ² 91M02

¹ Certified in accordance with USE certification program which is based on ARI Standard 210/240; 95°F outdoor air temperature, 80°F db / 67°F wb entering evaporator air with 25 ft. of connecting refrigerant lines.

² **Factory installed RFC or expansion valve on indoor unit MUST be replaced with expansion valve kit (ordered separately).**

³ Blower must be capable of time-off blower delay. Indoor Blower Off Delay Relay (**58M81**) is recommended for field installation.

⁴ Blower control must be set for a time-off blower delay.

⁵ Most popular indoor coil.

ARI RATINGS

¹ ARI Standard 210/240 Ratings

Cooling Capacity Btuh	Efficiency		Total Unit Watts	Indoor Unit Model No.	Expansion Device
	SEER	EER			
SSB060H4					5 TON
Horizontal Indoor Coils				Horizontal Coils	
56,000	13.20	10.90	5135	³ CH23-65	² 91M02
57,500	13.70	11.00	5155	³ CH33-60D-2F	² 91M02
58,000	13.70	11.20	5160	³ CH33-50/60C-2F	² 91M02
58,000	13.70	11.20	5160	³ CH33-62D-2F	² 91M02
60,000	13.70	11.20	5245	³ CH23-68	² 91M02
Horizontal Indoor Coils + Furnace				Horizontal Coils + Furnace	
58,000	14.20	11.20	5140	CH33-50/60C-2F ⁴ G61MPV-60C-090	² 91M02
58,000	14.20	11.20	5155	CH33-50/60C-2F ⁴ G61MPV-60C-110	² 91M02
58,000	14.20	11.20	5180	CH33-62D-2F ⁴ G61MPV-60C-110	² 91M02
58,000	14.20	11.20	5180	CH33-62D-2F ⁴ G61MPV-60C-111	² 91M02
58,000	14.50	11.20	5100	CH33-50/60C-2F ⁴ G60UHV-60C-110	² 91M02
58,000	14.50	11.20	5180	CH33-62D-2F ⁴ G61MPV-60C-090	² 91M02
58,000	14.50	11.20	5180	CH33-62D-2F ⁴ G61MPV-60C-091	² 91M02
58,000	14.70	11.50	5015	CH33-60D-2F ⁴ G61MPV-60D-135	² 91M02
58,000	14.70	11.50	5020	CH33-62D-2F ⁴ G61MPV-60D-135	² 91M02
58,000	14.70	11.50	5045	CH33-62D-2F ⁴ G60UHV-60C-110	² 91M02
58,500	14.70	11.20	5100	CH33-50/60C-2F ⁴ G60UHV-60C-090	² 91M02
58,500	14.70	11.50	5085	CH33-62D-2F ⁴ G60UHV-60C-090	² 91M02
58,500	15.00	11.50	5020	CH33-60D-2F ⁴ G60UHV-60D-135	² 91M02
59,000	15.00	11.70	5025	CH33-62D-2F ⁴ G60UHV-60D-135	² 91M02
Air Handlers				Air Handlers	
54,500	12.30	10.20	5330	³ CB29M-65 (Multi-Position)	91M02
58,000	15.00	11.50	5035	⁴ CBX32MV-048 (Multi-Position)	Factory TXV
58,500	14.20	11.20	5175	³ CB30U-65 (Up-Flow)	² 91M02
57,500	14.70	11.50	5000	⁴ CBX27UH-060 (Up-Flow / Horizontal)	Factory TXV
58,500	15.00	11.50	5035	⁴ CBX32MV-060 (Multi-Position)	Factory TXV
58,500	15.00	11.70	4965	⁴ CBX32MV-068 (Multi-Position)	Factory TXV
59,000	14.20	11.50	5120	³ CBX32M-060 (Multi-Position)	Factory TXV
60,000	14.50	11.70	5130	CBX26UH-060 (Up-Flow / Horizontal)	Factory TXV

¹ Certified in accordance with USE certification program which is based on ARI Standard 210/240; 95°F outdoor air temperature, 80°F db / 67°F wb entering evaporator air with 25 ft. of connecting refrigerant lines.

² **Factory installed RFC or expansion valve on indoor unit MUST be replaced with expansion valve kit (ordered separately).**

³ Blower must be capable of time-off blower delay. Indoor Blower Off Delay Relay (**58M81**) is recommended for field installation.

⁴ Blower control must be set for a time-off blower delay.

⁵ Most popular indoor coil.

REVISIONS

Sections	Description of Change
Dimensions	Added new base section view.
Guide Specifications	Added Guide Specifications.

GUIDE SPECIFICATIONS

This specification specifies [**Lennox SSB S-Class®**] split system air conditioners. These products are manufactured by Lennox Industries. Revise section number and title below to suit project requirements, specification practices and section content. Refer to CSI *MasterFormat* for other section numbers and titles.

Optional text and text that requires a decision are indicated by **bold brackets []**, and proprietary information is indicated by **bold italic brackets []**; delete text that is not needed in final copy of specification. Specifier Notes typically precede specification text; delete notes in final copy of specification. Trade/brand names with appropriate symbols typically are used in Specifier Notes; symbols are not used in specification text. Metric conversion, where used, is soft metric conversion.

SECTION 23 81 26

SPLIT-SYSTEM AIR-CONDITIONERS

PART 1 GENERAL

PART 1.01 SUMMARY

- A. Section Includes: Split System Air Conditioners, including:
 - 1. Cabinet
 - 2. Compressor
 - 3. Refrigerant system
 - 4. Controls
 - 5. Refrigerant line connectors, electrical inlets and service valves

Specifier Note: Revise paragraph below to suit project requirements. Add section numbers and titles per CSI *MasterFormat* and specifier's practice.

Specifier Note: Article below may be omitted when specifying manufacturer's proprietary products and recommended installation. Retain Reference Article when specifying products and installation by an industry reference standard. If retained, list standard(s) referenced in this section. Indicate issuing authority name, acronym, standard designation and title. Establish policy for indicating edition date of standard referenced. Conditions of the Contract or Division 01 References Section may establish the edition date of standards. This article does not require compliance with standard, but is merely a listing of references used. Article below should list only those industry standards referenced in this section. Retain only those reference standards to be used within the text of this Section. Add and delete as required for specific project.

PART 1.02 REFERENCES

- A. Air-Conditioning and Refrigeration Institute (ARI):
 - 1. ARI 210/240 – 2005, Unitary Air-Conditioning and Air-Source Heat Pump Equipment.
 - 2. ARI 270 – 1995, Sound Rating of Outdoor Unitary Equipment.
- B. Servicing Standards:
 - 1. Underwriters Laboratories, Inc.® (UL)
 - 2. Canadian Electric Code (CEC)
 - 3. Underwriters Laboratories of Canada® (ULC)
- C. Department of Energy (DOE), units rated to
- D. ISO 9001 registered manufacturing quality system
- E. Units to Be Energy Star® compliant

Specifier Note: Article below should be restricted to statements describing design or performance requirements and functional (not dimensional) tolerances of a complete system. Limit descriptions to composite and operational properties required to link components of a system together and to interface with other systems.

PART 1.03 SYSTEM DESCRIPTION

- A. Performance Requirements:

GUIDE SPECIFICATIONS

Specifier Note: Refer to Lennox Engineering Handbook for specific heating and cooling capacities. Units are available in 3, 4 and 5 ton models. Cooling capacities vary from 33,400 to 60,500 Btuh.

1. 3, 4 and 5 ton capacity.
2. Electrical Characteristics:
 - a. 60 Hz.
 - b. 3-phase.
 - c. [208/230 V] [460 V].

Specifier Note: Article below includes submittal of relevant data to be furnished by Contractor before, during or after construction. Coordinate this article with Architect's and Contractor's duties and responsibilities in Conditions of the Contract and Division 01 Submittal Procedures Section.

PART 1.04 SUBMITTALS

- A. General: Submit listed submittals in accordance with Conditions of the Contract and Division 01 Submittal Procedures.
- B. Product Data: Submit product data for specified products.
- C. Shop Drawings:
 1. Submit shop drawings in accordance with Section [01 33 00 - Submittal Procedures] [_____].
 2. Indicate:
 - a. Equipment, piping and connections, together with valves, strainers, control assemblies, thermostatic controls, auxiliaries and hardware, and recommended ancillaries that are mounted, wired and piped ready for final connection to building system, its size and recommended bypass connections.
 - b. Piping, valves and fittings shipped loose showing final location in assembly.
 - c. Control equipment shipped loose, showing final location in assembly.
 - d. Field wiring diagrams.
 - e. Dimensions, internal and external construction details, installation clearances, recommended method of installation, sizes and location of mounting boltholes.
 - f. Detailed composite wiring diagrams for control systems showing factory installed wiring and equipment on split systems or required for controlling devices or ancillaries, accessories, controllers.
- D. Quality Assurance:
 1. Test Reports: Certified test reports showing compliance with specified performance characteristics and physical properties.
 2. Certificates: Product certificates signed by manufacturer certifying materials comply with specified performance characteristics and criteria and physical requirements.
 3. Manufacturer's Instructions: Manufacturer's installation instructions.

Specifier Note: Coordinate paragraph below with Part 3 Field Quality Requirements Article. Retain or delete as applicable.

- E. Manufacturer's Field Reports: Manufacturer's field reports specified.
- F. Closeout Submittals: Submit the following:
 1. Warranty: Warranty documents specified.
 2. Operation and Maintenance Data: Operation and maintenance data for installed products in accordance with Division 01 Closeout Submittals (Maintenance Data and Operation Data) Section. Include methods for maintaining installed products, and precautions against cleaning materials and methods detrimental to finishes and performance. Include names and addresses of spare part suppliers.
 3. Provide brief description of unit, with details of function, operation, control and component service.
 4. Commissioning Report: Submit commissioning reports, report forms and schematics in accordance with Section [01 91 00 - Commissioning] [_____].

PART 1.05 QUALITY ASSURANCE

- A. Qualifications:
 1. Installer experienced in performing work of this section who has specialized in installation of work similar to that required for this project.
 2. Manufacturer Qualifications: Manufacturer capable of providing field service representation during construction and approving application method.
- B. Preinstallation Meetings: Conduct pre-installation meeting to verify project requirements, manufacturer's installation instructions and manufacturer's warranty requirements. Comply with Division 01 Project Management and Coordination (Project Meetings).

GUIDE SPECIFICATIONS

PART 1.06 DELIVERY, STORAGE & HANDLING

- A. General: Comply with [01 61 00 - Common Product Requirements] [_____].
- B. Ordering: Comply with manufacturer's ordering instructions and lead-time requirements to avoid construction delays.
- C. Packing, Shipping, Handling and Delivery:
 - 1. Deliver materials in manufacturer's original, unopened, undamaged containers with identification labels intact.
 - 2. Ship, handle and unload units according to manufacturer's instructions.
- D. Storage and Protection:
 - 1. Store materials protected from exposure to harmful weather conditions.
 - 2. Factory shipping covers to remain in place until installation.

Specifier Note: Include or remove following section as project dictates.

- E. Waste Management and Disposal:

Specifier Note: ENVIRONMENT: The disposal of packaging waste into landfill site demonstrates an inefficient use of natural resources and consumes valuable landfill space.

- 1. Separate waste materials for [Reuse] [And] [Recycling] [_____] in accordance with Section [01 74 19 - Construction Waste Management and Disposal] [_____].
- 2. Remove from site and dispose of packaging materials at appropriate recycling facilities.
- 3. Collect and separate for disposal [Paper] [Plastic] [Polystyrene] [Corrugated cardboard] [_____] packaging material [In appropriate onsite bins] [_____] for recycling.

Specifier Note: Coordinate article below with Conditions of the Contract and with Division 01 Closeout Submittals (Warranty).

PART 1.07 WARRANTY

- A. Project Warranty: Refer to Conditions of the Contract for project warranty provisions.
- B. Manufacturer's Warranty: Submit, for Owner's acceptance, manufacturer's standard warranty document executed by authorized company official. Manufacturer's warranty is in addition to, and not a limitation of, other rights Owner may have under Contract Documents.

Specifier Note: Coordinate paragraph below with manufacturer's warranty requirements.

- C. Warranty: Commencing on Date of Installation.
 - 1. Compressor: Five years (limited) (non-residential)
 - 2. Other Covered Components: One year (limited) (non-residential)

GUIDE SPECIFICATIONS

PART 2 PRODUCTS

Specifier Note: Retain article below for proprietary method specification. Add product attributes, performance characteristics, material standards, and descriptions as applicable. Use of such phrases as “or equal” or “or approved equal” or similar phrases may cause ambiguity in specifications. Such phrases require verification (procedural, legal and regulatory) and assignment of responsibility for determining “or equal” products.

PART 2.01 AIR CONDITIONERS/SPLIT SYSTEM UNITS

A. Manufacturer: **[Lennox Industries]**

1. Contact: **[2100 Lake Park Blvd., Richardson, TX 75080; Telephone: (800) 453-6669; website: www.lennox.com]**

B. **[Proprietary]** Products/Systems: **[SSB, S-Class®]** Split System Air Conditioner Units, including the following equipment:

1. All units to be factory assembled, wired and piped
2. All units to be assembled in the USA
3. All units to be factory tested prior to shipping
4. Cabinet:
 - a. Heavy-gauge steel construction
 - b. Corrosion free pre-painted cabinet finish
 - c. Corrosion free pre-painted base section
 - d. Control box with controls factory wired
 - e. Large removable service access panel
 - f. Base drainage holes for moisture removal
 - g. High density polyurethane unit support feet
 - h. Coil protection panels
 - 1) **[SmarHinge™]**
 - 2) Steel
 - 3) Hinged
 - 4) Louvered
 - 5) May be completely removable
 - i. Refrigerant Line Connections, Electrical Inlets, Service Valves:
 - 1) Sweat connection vapor and liquid lines located on cabinet corner
 - 2) Fully serviceable brass service valves
 - 3) Full shutoff Vapor valve
 - 4) Liquid valve can be front seated to manage refrigerant charge while servicing system
 - 5) Suction and Liquid line service valve to be located inside unit
 - 6) Suction and Liquid line gauge ports to be located inside unit
 - 7) Refrigerant line connections and field wiring inlets to be located in one central area

5. **[Controls Options:]**

- a. **[Indoor Blower Speed Relay Kit]**
- b. **[Time Delay Relay Kit]**
- c. **[Low Ambient Kit (down to 30° F)]**
- d. **[Low Ambient Control Kit (down to 0° F)]**
- e. **[Compressor Low Ambient Cutoff]**
- f. **[Compressor Time Off Control]**
- g. **[Commercial Touchscreen Thermostat by Lennox]**
- h. **[Compressor Lock-out Thermostat]**

6. Compressor:

- a. Two Stage
- b. Scroll type
- c. Resiliently mounted on rubber mounts for vibration isolation
- d. Internal excessive current and temperature protection
- e. Crankcase heater

GUIDE SPECIFICATIONS

7. Refrigerant System:
 - a. Refrigerant: R410-A
 - b. Outdoor Coil Fan:
 - 1) Direct drive fan
 - 2) Vertical air discharge
 - 3) Totally enclosed fan motor with sleeve bearings
 - 4) Fan motor to be inherently protected
 - 5) Corrosion resistant PVC coated steel fan guard
 - 6) Removable fan guard for fan service access
 - c. Copper Tube/Fin Coil:
 - 1) Copper tube
 - 2) Flared shoulder connections
 - 3) Silver solder construction
 - 4) Lanced, ripple-edged aluminum fins
 - 5) Coil is leak tested at factory
 - 6) Entire coil to be accessible for cleaning
 - d. Factory installed standard features:
 - 1) High pressure switch
 - 2) Low pressure switch
 - 3) High capacity liquid line drier
 - e. **[Options:]**
 - 1) **[Expansion valve kit]**
 - 2) **[Freezestat]**
 - 3) **[Refrigerant line kit]**
8. See manufacturers documentation for matching add-on furnaces
9. Installer must:
 - a. Set air conditioner
 - 1) Connect refrigerant lines
 - 2) Make electrical connections

Specifier Note: Edit article below to suit project requirements. If substitutions are permitted, edit text below. Add text to refer to Division 01 Project Requirements (Product Substitutions Procedures) Section.

PART 2.02 PRODUCT SUBSTITUTIONS

- A. Substitutions: No substitutions permitted.

PART 3 EXECUTION

PART 3.01 MANUFACTURER'S INSTRUCTIONS

Specifier Note: Revise article below to suit project requirements and specifier's practice.

- A. Compliance: Comply with manufacturer's written data, including product technical bulletins, product catalog installation instructions and product carton installation instructions.

PART 3.02 EXAMINATION

- A. Site Verification of Conditions: Verify that substrate conditions, which have been previously installed under other sections, are acceptable for product installation in accordance with manufacturer's instructions.

PART 3.03 INSTALLATION

- A. Install air conditioner in accordance with manufacturer's instructions and regulations of authorities having jurisdiction.

END OF SECTION



**ARI Standard
210/240 UAC**



Visit us at www.lennox.com
For the latest technical information, www.lennoxcommercial.com
Contact us at 1-800-4-LENNOX

NOTE - Due to Lennox' ongoing commitment to quality, Specifications, Ratings and Dimensions subject to change without notice and without incurring liability. Improper installation, adjustment, alteration, service or maintenance can cause property damage or personal injury. Installation and service must be performed by a qualified installer and servicing agency.

©2007 Lennox Industries Inc.